

SGM-250CX / SGM-250MX

PROFESSIONAL COMPACT
CINE MIC

English

Owner's Manual



 AZDEN®

Product Highlights

- Newly developed electret condenser microphone element delivers the best sensitivity and lowest noise in its class
- Compact design works great with cinema cameras and for mounting on top of mirrorless cameras
- Powered by standard 48 V DC phantom power
- Custom designed acoustic tube with high precision phase canceling slots produces a flat frequency response with excellent directionality and wide dynamic range
- Brass/aluminum alloy case for improved durability and resistance to ambient RF
- CX model: Gold plated, 3-pin XLR output connector with 33 cm wire extension
- MX model: 3-pin mini-XLR output connector with 33 cm wire extension

Overview

The SGM-250CX and SGM-250MX are short length, condenser shotgun microphones that are ideal for mounting on video cameras equipped with XLR microphone inputs. As part of Azden's 250 microphone model series, you can expect professional quality sound that preserves the natural characteristics of a speaking subject. The supercardioid pickup pattern will also minimize the recording of extraneous noise and better focus on the sound in front of the camera.

Integrated with each microphone's design is a hardwired XLR cable for convenient connection to camera microphone inputs. The CX model includes a standard, 3-pin XLR output connector for equipment with standard XLR microphone inputs. The MX model includes a 3-pin mini-XLR connector for equipment with mini-XLR microphone inputs.

This microphone's highly sensitive, condenser element is powered by standard 48 V phantom power, which most standard and mini XLR microphone inputs can provide. The microphone includes Azden's SMH-X shock mount which attaches to a standard size camera shoe slot, as well as 1/4"- 20 threaded mounts and tripods. Also included are diameter expander sheets for universal compatibility with ring-clamp style microphone mounts.

Power

Phantom power is a DC voltage supplied through a balanced microphone cable and used to power the electronics of the connected microphone. Most professional cameras, mixers and audio interfaces with microphone XLR preamps have the ability to supply phantom power. If the equipment you use does not, you will have to utilize a separate external phantom power supply.

Most commonly, phantom power is supplied at 48 V. This is the optimum voltage for the SGM-250CX and SGM-250MX. It is possible that your connecting equipment supplies a different voltage. This microphone is rated to work on a voltage between 11 and 50 V, however, performance will degrade with lower voltages and damage to the electronics could result when using voltages in excess of this range. It is recommended that you consult the manuals of any equipment you intend to use with the microphone beforehand. Please note that the warranty does not cover damage caused by using phantom power beyond what the microphone is rated for.

Connecting to Camera

To connect the SGM-250CX to a camera, it must have a standard 3-pin XLR microphone input available. To connect the SGM-250MX to a camera, it must have a 3-pin mini-XLR microphone input available. The input must also supply phantom power.

Be aware that for some cameras, it is required that you change the audio settings in order to use audio from an external microphone. Please check your camera's manual.

Diameter Expander Sheets

The SGM-250CX and SGM-250MX come with two diameter expander sheets. These sheets are made from flexible rubber, have an adhesive backing, and are meant to be wrapped around the base of the microphone to allow it to better fit in ring-clamps larger than \varnothing 21 mm. Be careful not to cover the cancellation slots of the microphone barrel when using the expander sheets.

Specifications

Freq. Response:	20 Hz – 20 kHz
Polar Pattern:	Supercardioid
Sensitivity:	-33 dB at 1 kHz (0 dB = 1 V/Pa)
Dynamic Range:	112 dB
Impedance:	100 Ω (at 1 kHz)
Max Input SPL:	130 dB SPL (1 kHz at 1% T.H.D.)
S/N Ratio:	76 dB (1 kHz at 1 Pa)
Power Requirement:	DC 11-50 V Phantom
Output:	3-pin XLR / mini-XLR
Dimensions:	153 mm x \varnothing 21 mm (6.02" x \varnothing 0.83") (Length x Diameter)
Cable:	\varnothing 5 mm x 330 mm
Weight:	85 g (2.99 oz)
Accessories:	Shock mount holder, windscreen, carrying pouch, rubber sheets

XLR pin assignments

3 Pin XLR Male
SGM-250CX

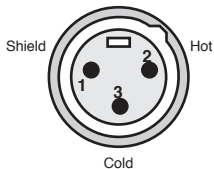

3 Pin Mini XLR Male
SGM-250MX

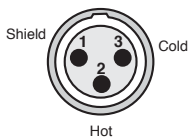

Frequency Response

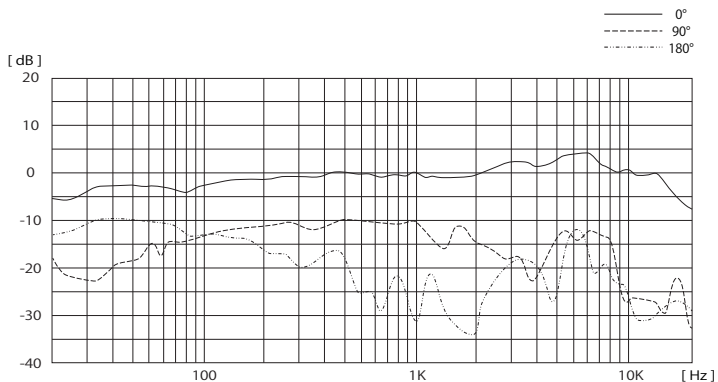

Polar Pattern

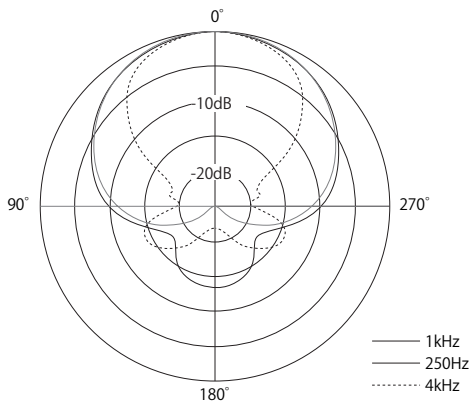

Included Accessories



Shock absorbing
camera-mount mic clip (SMH-X)



High quality foam windscreen



Carrying pouch



Rubber diameter
expander sheets



CAUTION



Do not attempt to open the casing or make any modification to the internal electrical components. Electric shock or injury may result. Any unauthorized modification to this product will void all applicable warranties.

Do not store or operate this product near a heat source or in an environment of extreme temperatures. Avoid exposure to rain or any other source of moisture. Do not submerge in water. If exterior is exposed to water, wipe dry before use.

Please take the time to read this manual carefully and keep it for your reference.

REGISTER FOR THE 10 YEAR WARRANTY



Congratulations on your purchase of the Azden SGM-250CX / SGM-250MX Professional Compact Cine Mic.

All Azden products come with a two (2) year limited warranty. The warranty for the SGM-250CX and SGM-250MX may be extended to ten (10) years.

To obtain the 10 year warranty, please register your microphone online at warranty.azden.com/register* within 90 days from the date of purchase.

**Azden's 10 year warranty is not available in all countries and not all Azden products are eligible. See www.azden.com for details.*

Azden Two Year Limited Warranty

Azden Corporation warrants, to the first purchaser, that the Azden brand product purchased is free from defects in material and workmanship. Azden's sole obligation under this warranty shall be to provide, without charge, repair or replacement (at Azden's sole discretion), within two years from the date of purchase. A dated receipt is required to establish the date of purchase and no registration is necessary to receive warranty service under this two year limited warranty. The cost to ship a failed product to and from Azden or to its dealer shall not be covered by this warranty.

This warranty is the sole and exclusive express warranty given with respect to the product and all other warranties, expressed or implied, are hereby excluded. Neither Azden, nor the dealer who sells this product, is responsible for indirect, incidental or consequential damages.

This warranty does not extend to any defect, malfunction or failure caused by misuse, abuse, accident, act of God, faulty hookup, unauthorized modification, connecting this product to equipment for which this product is not intended or defective associated equipment.

Customers in the Asia and Oceania markets contact:
Azden Corp., 1-12-17 Kamirenjaku Mitaka-shi, Tokyo, 181-8533 Japan
Tel: +81-422-55-5115 (Japan) • Fax: +81-422-55-0131 (Japan)
www.azden.co.jp • email: sales@azden.co.jp

Customers in the North/South America and European markets contact:
Azden Corp., 200 Valley Road, Suite 101, Mt. Arlington, NJ 07856
Tel: +1-973-810-3070 • Fax: +1-973-810-3076
www.azden.com • email: sales@azden.com