

# TAMRON | Model: A057 Owner's manual

## 150-500mm F/5-6.7 Di III VC VXD

For Sony E  
For FUJIFILM X (APS-C)

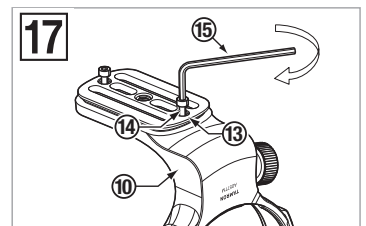
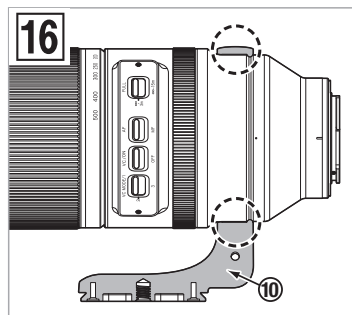
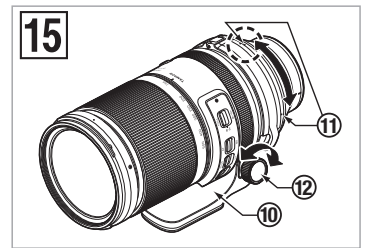
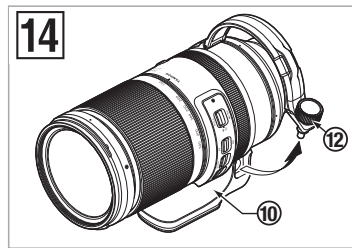
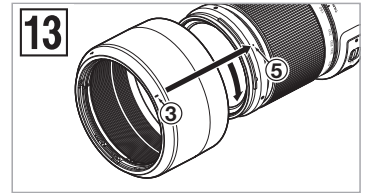
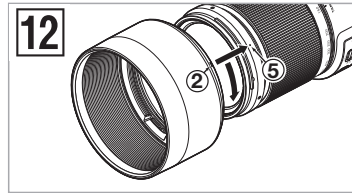
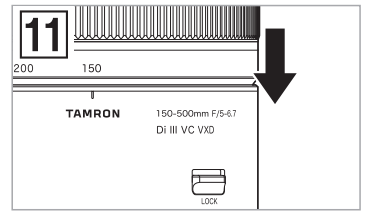
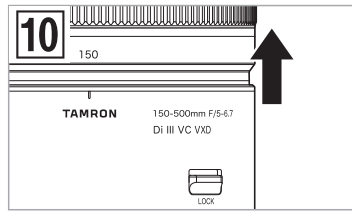
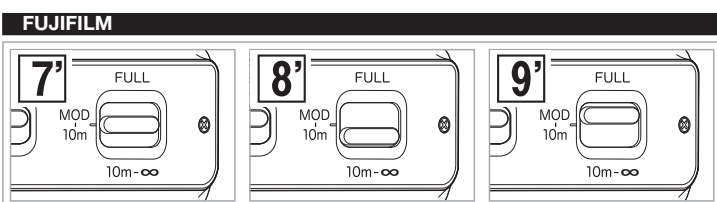
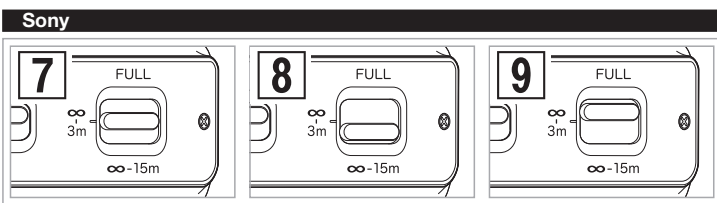
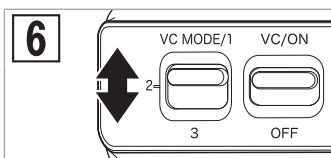
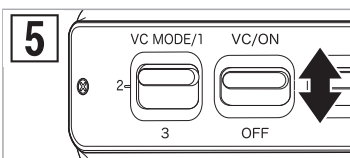
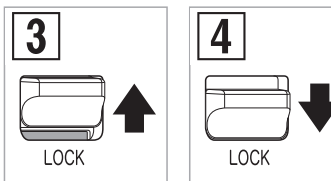
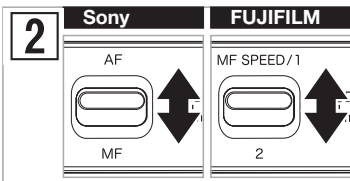
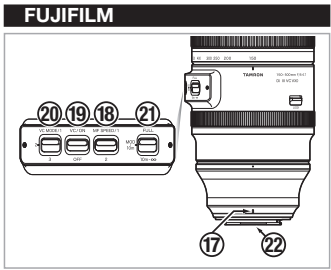
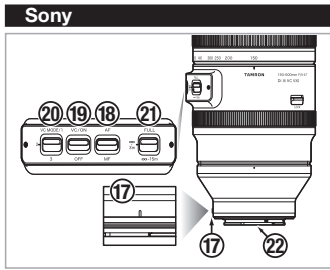
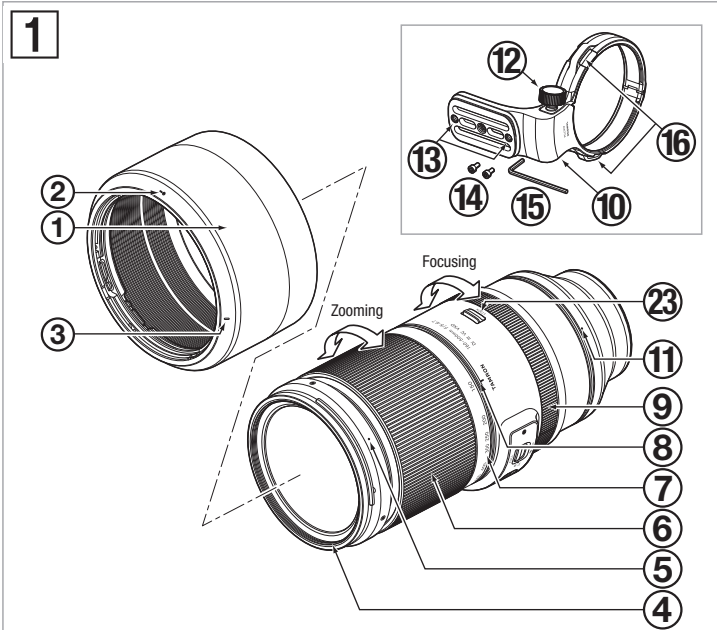

**For FUJIFILM X Mount Lens**

FreeRTOS Kernel V10.3.1  
Copyright (C) 2020 Amazon.com, Inc. or its affiliates. All Rights Reserved.

Permission is hereby granted, free of charge, to any person obtaining a copy of this software and associated documentation files (the "Software"), to deal in the Software without restriction, including without limitation the rights to use, copy, modify, merge, publish, distribute, sublicense, and/or sell copies of the Software, and to permit persons to whom the Software is furnished to do so, subject to the following conditions:

The above copyright notice and this permission notice shall be included in all copies or substantial portions of the Software.

THE SOFTWARE IS PROVIDED "AS IS", WITHOUT WARRANTY OF ANY KIND, EXPRESS OR IMPLIED, INCLUDING BUT NOT LIMITED TO THE WARRANTIES OF MERCHANTABILITY, FITNESS FOR A PARTICULAR PURPOSE AND NONINFRINGEMENT. IN NO EVENT SHALL THE AUTHORS OR COPYRIGHT HOLDERS BE LIABLE FOR ANY CLAIM, DAMAGES OR OTHER LIABILITY, WHETHER IN AN ACTION OF CONTRACT, TORT OR OTHERWISE, ARISING FROM, OUT OF OR IN CONNECTION WITH THE SOFTWARE OR THE USE OR OTHER DEALINGS IN THE SOFTWARE.

<http://www.FreeRTOS.org>  
<http://aws.amazon.com/freertos>

**CE** \* The CE Marking is a directive conformity mark of the European Community (EC).  
\* Das CE-Zeichen entspricht der EC Norm.  
\* La marquage CE est un marquage de conformité à la directive CEE (CE).  
\* La marca CE es marca de conformidad según directiva de la Comunidad Europea (CE).  
\* Il marchio CE attesta la conformità alla direttiva della Comunità Europea (CEE).  
\* CE 标志表示符合欧洲共同体(CE)指标

**CE** The EEC Conformity Report applies to the Council Directive 2014/30/EU, 2011/65/EU and is used by Tamron Co., Ltd., manufacturer of this product.

# ENGLISH

Thank you for purchasing this Tamron lens. Before using your new lens, please read the contents of this Owner's manual to properly use the lens. Also, it will be important to read the manual of the camera to which you will attach the lens.

After reading, store this Owner's manual in a safe place.

Please read also the document "Precautions for Safe Use of Tamron Lenses" supplied with the lens for the detailed safety precautions to observe when using Tamron lenses.



- Explains precautions that help to prevent problems.



- Explains things you should know in addition to basic operations.

## PART NAMES (Refer to Fig. 1)

- |                                      |  |
|--------------------------------------|--|
| ① Lens hood                          | ⑫ Hood attaching alignment mark                                |
| ③ Hood locking mark                  | ④ Filter ring  |
| ⑤ Hood release mark                  | ⑥ Zooming ring   |
| ⑦ Focal length scale                 | ⑧ Focal length mark  |
| ⑨ Focus ring                         | ⑩ Tripod mount   |
| ⑪ Tripod mount mark                  | ⑬ Tripod mount locking screw                                   |
| ⑬ Screw hole for safety lock screw   | ⑭ Safety lock screw (x2)                                       |
| ⑮ Hexagonal wrench                   | ⑯ Strap hole   |
| ⑰ Lens attachment mark               | ⑱ AF/MF switch (For Sony E) / MF SPEED switch (For FUJIFILM X) |
| ⑲ VC (Vibration Compensation) switch | ⑳ VC mode switch   |
| ㉑ Focus limiter switch               | ㉒ Lens-camera interface contacts                               |
| ㉓ Wide-end zoom lock switch          |  |



- Before using the lens, make sure to remove the tape on lens surface.

## MAIN SPECIFICATIONS

Model	A057
Focal Length	150-500 mm
Maximum Aperture	F/5-6.7
Angle of View (diagonal)	16°25' - 4°57' / 10°59' - 3°18' (APS-C)
Optical Construction	16/25
Minimum Object Distance (MOD)	0.6 m (23.6") (Wide) / 1.8 m (70.9") (Tele)
Maximum Magnification Ratio	1.3:1 (Wide MOD) / 1.3:7 (Tele MOD)
Filter Size	ø 82 mm
Length	209.6 mm (8.3") / Sony E, 209.9 mm (8.3") / FUJIFILM X
Maximum Diameter	ø 93 mm
Weight	1,725 g (60.8 oz) / Sony E, 1,710 g (60.3 oz) / FUJIFILM X (without tripod mount), Tripod mount 155 g (5.5 oz)
Lens Hood	HA057



- Length : From tip of front element to mount surface.
- Specifications, appearance, functionality, etc. are subject to change without prior notice.

## ATTACHING AND REMOVING THE LENS

Remove the rear cap of the lens. Align the lens attachment mark ⑰ and mounting mark on the camera, and then insert the lens.

Turn the lens clockwise until it locks.

To remove the lens, turn the lens in the opposite direction while pressing the lens release button on the camera.



- Turn off the power of the camera before attaching or removing the lens.



- For details, please read the instruction manual of your camera.

## SWITCHING FOCUS MODE (Ref. Figs. 1, 2)

### ■ For Sony E: AF/MF Switching (Ref. Figs. 1, 2)

To shoot using autofocus (AF), set both the camera and the AF/MF switch ⑱ on the lens to "AF". (Ref. Fig. 2) (If the lens is set at "MF", it will not autofocus.)

To shoot using manual focus (MF), set the camera and/or the lens AF/MF switch ⑱ to "MF".

For manual focus, turn the focus ring ⑨ to acquire the focus. (Ref. Figs. 1, 2)

### ■ For FUJIFILM X: MF SPEED Switching (Ref. Figs. 1, 2)

When you choose "MANUAL FOCUS" on the camera body, you may select the focus response speed by the selector switch ⑱ on the lens.

MODE 1 For normal focusing, average response speed

MODE 2 For precise focusing, slower response speed



- Under AF mode, there may be difficulty for autofocus to work depending on the subject.
- For Sony E mount lens, if your camera features an AF/MF control button, it is possible to temporarily switch to MF from AF by pressing the AF/MF control button. When the lens set to "AF" and the camera set to "MF", by pressing the AF/MF control button you may temporarily switch the focus to AF.



- For details, please read the instruction manual of your camera.

## VIBRATION COMPENSATION MECHANISM (Ref. Figs. 1, 5, 6)

To compensate for the vibrations, set the VC (Vibration Compensation) switch ⑲ to ON. (Ref. Fig. 5)

### ■ Switching the modes (Ref. Fig. 6)

You can switch the modes by using the VC mode switch ⑳.

MODE 1 Basic vibration compensation mode

MODE 2 Panning mode

MODE 3 Mode that prioritizes framing. Makes it easier to maintain subjects moving quickly within the frame.

\* MODE 1 and MODE 3 do not support panning.

### ● Vibration compensation is effective under the following conditions

- Dimly lit locations
- Locations where flash photography is prohibited
- Locations where tripod cannot be used

### ● Vibrations may not be compensated sufficiently under the following conditions

- When a photograph is taken from a vehicle that is shaking greatly
- Shooting during excessive movement of the camera
- When shooting while using a tripod
- Set the VC switch ⑲ to OFF when taking pictures with bulb photography (long exposures). Otherwise, vibration compensation may cause a malfunction.



- When MODE 1 or MODE 2 is set, the viewfinder image may become blurred immediately after the shutter button is pressed halfway. This is due to the principles of the vibration compensation mechanism and not a malfunction.
- When MODE 3 is set, the viewfinder image may become blurred even without touching the shutter button in the case the camera is turned on with the VC switch ⑲ set to ON. This is due to the principles of the vibration compensation mechanism and not a malfunction.
- Set the VC switch ⑲ to OFF when you are shooting while the camera is secured by something other than your hand (such as a tripod).
- You may feel the lens rattle when the camera is turned off or when the lens is removed from the camera. This is not a malfunction.



- For details, please read the instruction manual of your camera.

## USING THE FOCUS LIMITER (Ref. Figs. 1, 7 - 9 for Sony E / 7 - 9 for FUJIFILM X)

When autofocus is set, switching the focus limiter switch ㉑ can speed up focusing by limiting the focus range.

### For Sony E mount lens

#### ■ To limit the autofocus range to subjects from infinity to 3 m (Ref. Fig. 7)

Set the focus limiter switch ㉑ to "∞-3m".

#### ■ To limit the autofocus range to subjects from infinity to 15 m (Ref. Fig. 8)

Set the focus limiter switch ㉑ to "∞-15m".

#### ■ When not using the focus limiter (Ref. Fig. 9)

Set the focus limiter switch ㉑ to "FULL".

### For FUJIFILM X mount lens

#### ■ To limit the autofocus range to subjects from MOD\* to 10 m (Ref. Fig. 7)

Set the focus limiter switch ㉑ to "MOD-10m".

#### ■ To limit the autofocus range to subjects from 10 m to infinity (Ref. Fig. 8)

Set the focus limiter switch ㉑ to "10m-∞".

#### ■ When not using the focus limiter (Ref. Fig. 9)

Set the focus limiter switch ㉑ to "FULL".

\*MOD: Minimum Object Distance

## ZOOMING (Ref. Fig. 1)

Turn the zooming ring ⑥ to adjust the focal length (Zoom position) to a desired position.

## WIDE-END ZOOM LOCK MECHANISM (Ref. Figs. 1, 3, 4)

You can lock the zooming ring ⑥ at a focal length of 150 mm to keep it from rotating.

### ■ Setting the zoom lock (Ref. Fig. 3)

Align 150 mm on the focal length scale ⑦ with the focal length mark ⑧.

Set the wide-end zoom lock switch ㉓ to the zooming ring side.

### ■ Releasing the zoom lock (Ref. Fig. 4)

Set the wide-end zoom lock switch ㉓ to the camera side.



- To zoom, release the lock, and then rotate the zooming ring ⑥.

## FLEX-ZOOM LOCK MECHANISM (Ref. Figs. 1, 10, 11)

This mechanism is intended to stop the lens from zooming inadvertently at any position.

Rotate the zooming ring ⑥ to the desired zoom position, and then apply the lock after you have determined the position.

### ■ Setting the zoom lock (Ref. Fig. 10)

Move the zooming ring ⑥ to the subject side until the white mark is visible.

### ■ Releasing the zoom lock (Ref. Fig. 11)

Move the zooming ring ⑥ to the camera side.



- During activities such as carrying the product, use the wide-end zoom lock to prevent zooming due to its own weight. (Ref. Figs. 1, 3)
- To zoom, release the flex-zoom lock, and then rotate the zooming ring ⑥.
- Take care not to get your fingers caught while you switch the flex-zoom lock.
- If the camera will not be used for an extended period, release the flex-zoom lock before storage.

## LENS HOOD (Ref. Figs. 1, 12, 13)

A bayonet-type lens hood ① is provided as standard equipment.

We recommend shooting with the hood properly attached because the lens hood eliminates stray light that may affect the picture.

### ■ Using the lens hood (Ref. Fig. 12)

Align the hood attaching alignment mark ② of the hood with the hood release mark ⑤ of the lens.

Rotate the hood ① in the direction of the arrow until the hood locking mark ③ meets the hood release mark ⑤.

### ■ Stowing the lens hood (Ref. Fig. 13)

You can stow the lens hood ① by attaching it in reverse.

Align the hood locking mark ③ of the hood with the hood release mark ⑤ of the lens.

Rotate the hood ① in the direction of the arrow until the hood attaching alignment mark ② meets the hood release mark ⑤.



- Be aware that the periphery of the photographed image may be darkened if the hood ① is not attached properly.

## TRIPOD MOUNT (Ref. Figs. 1, 14 - 16)

The A057 model comes with a tripod mount ⑩. When you use a tripod, lock the lens firmly to the tripod using the tripod mount ⑩.

### ■ Attaching and removing the tripod mount (Ref. Figs. 14, 16)

You can attach and remove the tripod mount by loosening tripod mount locking screw ⑫ and then lift the portion with the screw, to open the ring.

When attaching the tripod mount, make sure that the protruding part on the inner side of the tripod mount ⑩ is inserted into the groove on the lens, and then tightly secure the tripod mount locking screw ⑫.

If this protruding part is not inserted into the groove on the lens correctly when attaching the tripod mount ⑩, the lens may be damaged or fall off.

### ■ Changing the directional position of the camera (Ref. Fig. 15)

When you change the directional position of the camera, you can rotate the lens by loosening the tripod mount locking screw ⑫.

Align the tripod mount mark on the lens ① with the mark on the tripod mount ⑩.

After determining the shooting position, tightly secure the tripod mount locking screw ⑫ to fix the position.

### ■ Strap hole (Ref. Fig. 1)

You may pass a strap through these holes to prevent the lens from falling.

When using the strap holes ⑯ of the tripod mount ⑩, first check that the tripod mount locking screw ⑫ is firmly tightened, and then attach the strap securely. Note that the lens may fall if the tripod mount ⑩ or the strap detaches from the lens.

• The A057 tripod mount ⑩ can be attached to an ARCA-SWISS camera platform.

## SAFETY LOCK SCREW (Accessory for the tripod mount) (Ref. Figs. 1, 17)

We recommend attaching the lock screws in accordance with the camera platform type when you use an ARCA-SWISS-standard compatible camera platform or clamp.

### ■ How to use safety lock screws (Ref. Fig. 17)

The safety lock screws ⑭ prevent the lens/camera from falling from the camera platform when a tripod mount ⑩ is attached to an ARCA-SWISS-standard compatible camera platform or clamp.

As shown on the figure, use the hexagonal wrench ⑮ to tighten the safety lock screws ⑭ to the two screw holes ⑬.

• After attaching the safety lock screws ⑭, the screw heads protrude from the tripod mount ⑩ bottom surface to prevent the lens/camera from falling. For this reason, if you are using a camera platform or a clamp other than ARCA-SWISS-standard compatible, you do not need to have them attached.

## USAGE PRECAUTIONS

- An internal focusing (IF) system is employed to reduce the minimum focus distance. The angle of view may be wider than that of lenses with other focusing systems when shooting at a distance less than infinity.
- The lens hood or the lens barrel may block the light from the flash. It is recommended to perform trial shooting in advance.
- Differences in the display systems of cameras may cause to show values different from the maximum and minimum aperture values from the specifications. This is not an indication of an error.
- Do not touch the lens-camera interface contacts ⑳ with your fingers. Otherwise, it may cause a malfunction.
- If the temperature changes suddenly, condensation may form and cause malfunctions.
- The front lens is covered with stain-proof coating. After removing the dust on the lens surface with a blower or another means, wipe it with a dry cloth.
- Never use benzene, thinner, or other organic solvents to clean the lens.
- Store the lens in a clean and well-ventilated place.
- For more details on the lens cleaning and storage, the compatibility with cameras, and other support information see our website. <https://www.tamron.jp/en/support/>



### Disposal of Electrical and Electronic Equipment in Private Households. Disposal of used Electrical & Electronic Equipment (Applicable in the European Union and other European countries with separate collection systems)

This symbol indicates that this product shall not be treated as household waste. Instead it shall be collected separately for the recycling of electrical and electronic equipment.

If the new products are purchased, this product might be handed over to the distributor or the collection system of waste electrical and electronic equipment eventually.

By ensuring this product is disposed of correctly, you will help prevent potential negative consequences for the environment and human health, which could otherwise be caused by inappropriate waste handling of this product or components of this product.

If this product is disposed illegally, it might cause a possibility of penalties. For more detailed information about recycling of this product, please contact your local Civic Office, your household waste disposal service or the shop where you purchased the product.

**TAMRON****ENGLISH**

## Precautions for Safe Use of Tamron Lenses

For safe operation be sure to carefully read the "Precautions for Safe Use of Tamron Lenses" and the manual before using the product.

After reading them, store them in a place where they can easily be reviewed whenever needed.

Caution instructions are divided into the following two categories according to the degree of danger involved.

**WARNING**

This indicates instructions which if not followed or if performed incorrectly could lead to death or serious injury.

- Do not view the sun or other strong light source directly through the lens or through a camera while using this lens.  
Doing so could cause loss of vision, damage to the lens and/or the camera, and possibly cause the lens and/or camera to ignite.
- Do not disassemble, repair, or modify the lens.  
This could damage the lens or camera.
- Keep the lens out of the reach of small children.  
There is a risk of injury if the lens is dropped or falls down.

**CAUTION**

This indicates instructions which if not heeded or if performed incorrectly could lead to bodily injury or physical damage

- Do not place lens in direct sunlight or leave it in an extremely hot place such as inside a car. Doing such could damage the internal parts of the lens or cause a fire.
- Always attach the lens cap whenever the lens is not in use.
- When attaching the lens to the camera, ensure that the lens has been properly attached to the camera and firmly locked.  
If the lens is not attached properly, it could be difficult to remove or it could fall off causing damage or injury.
- Do not use this lens for any application other than photography.
- Do not carry around the lens while it is still attached to a tripod.
- Regarding the lens equipped with a connector port
  - 1) Place the lens in a stable location when customizing the lens using the dedicated application (TAMRON Lens Utility™). Make sure not to let it fall or impact the lens.
  - 2) When connecting the lens to a computer, use a Tamron connection cable (sold separately).
  - 3) Do not touch the connector port with your fingers or a metal object. Also, prevent dust or water from adhering to the connector port. If the connector port is dirty, it may cause connection problems.
- Tamron will not be responsible for damages caused by a failure, a fire, or other accidents that may occur when using an accessory other than Tamron accessories. Note that in case of such damage, repair of the Tamron lens will be charged since it is not covered by the warranty.