

Canon

RF

5.2mm F2.8 L DUAL FISHEYE

Instructions

ENG

Thank you for purchasing a Canon product.

Canon RF5.2mm F2.8 L DUAL FISHEYE is a 180° VR image production lens for use with EOS R series cameras.

- To get the most from your lens, we recommend using it under the following conditions.
 - Use Live View
 - Use a tripod
- These images can be converted to a 180° VR image using a camera application that supports the captured images.

Conventions used in these instructions



Warning to prevent lens or camera malfunction or damage.



Supplementary notes on using the lens and taking pictures.

Camera Firmware and Camera Applications

Please use the latest versions of firmware and applications with the camera in use. For details on whether the firmware and applications in use are the latest version or not, and for details on updating them, please check the Canon website.



This lens can be used with some cameras* in the EOS R series. If the camera does not support it, or the camera's firmware is not a compatible version, there may be issues with the camera operation.

* EOS R5 only (as of October 2021)

Safety Precautions

Precautions to ensure that the camera is used safely. Read these precautions thoroughly. Make sure all details are observed in order to prevent risks and injury to the user and other people.

Be sure to follow the instructions carefully when using the lens.



Warning

Details pertaining to risks that may result in death or serious injury.

- **Do not look directly at the sun or other strong light sources through a lens.** This may result in loss of sight.
- **Do not leave a lens in the sun without the lens cap attached.** The lens may concentrate entering sunlight and cause a malfunction or fire.



Caution

Details pertaining to risks that may result in injury or damage to other objects.

- **Do not leave the product in places exposed to extremely high or low temperatures.** The product may cause burns or injury when touched.
- **Do not shoot movies with extreme movement.** Viewing such movies may result in motion sickness-like symptoms.
- **Avoid shaking while shooting.** Viewing VR images taken while riding a vehicle or walking may result in feelings of fatigue or discomfort. When shooting such images, use of a tripod is recommended. Use the tripod to create a level view before shooting.

Safety Precautions

Be sure to follow the instructions carefully when viewing VR images.



Warning

Details pertaining to risks that may result in death or serious injury.

- **Those with an eye or heart condition or high blood pressure, pregnant women, and those with a history of spine disorders should consult with a doctor before viewing.** Viewing such images may cause symptoms to worsen.
- **Some individuals may experience muscle spasms, loss of consciousness, seizures, or other such symptoms while being subjected to stimuli such as bright lights or repeatedly blinking images. If you have ever experienced these sorts of problems, be sure to consult with a doctor before viewing.** Viewing such images may cause symptoms to worsen.
- **Extended continuous viewing the images by a person who has not yet finished developing may adversely affect the eyes or body.** Please pay attention to user's condition when viewing by anyone age 15 or younger. If you notice that the person has an abnormal physical condition, immediately stop using this device and see a doctor. Please use this device continuously for no longer than 3 minutes.



Caution

Details pertaining to risks that may result in injury or damage to other objects.

- **Those who cannot see the images clearly should refrain from viewing.** This may adversely affect the eyes or body.
- **Viewing the images by those who are unwell is not recommended.** This may cause feelings of nausea.
- **Those who are susceptible to motion sickness should consult with a doctor before viewing.** Viewing may cause the same symptoms to occur.
- **Do not view continuously for more than 30 minutes and allow your eyes and body to rest periodically.** Extended continuous viewing may adversely affect the eyes or body.
- **If you start to feel fatigued, discomfort, or any abnormality while viewing, discontinue viewing.** Continued viewing may affect your health.
- **Do not view images with either left or right display blocked, or while otherwise viewing drastically different images in left and right sides.** This may have a negative effect on the eyes or body.

General Precautions

Handling Precautions

- Do not leave the product in excessive heat such as in a car in direct sunlight. High temperatures can cause the product to malfunction.
- If the lens is taken from a cold environment into a warm one, condensation may develop on the lens surface and internal parts. To prevent condensation in this case, first put the lens into an airtight plastic bag before taking it from a cold to warm environment. Then take out the lens after it has warmed gradually. Do the same when taking the lens from a warm environment into a cold one.
- Please also read any lens related handling precautions listed in your camera's instruction manual.

Shooting Precautions

- This lens has a short focal length, which means dirt or dust on the surface of the lens will show up easily.
Use a commercially-available blower to remove dirt or dust from the lens surface or mount opening.
- Since this lens has a wide angle and the tip of the lens protrudes forward, the adjacent lens will appear in the image.
- When shooting hand-held shots, be careful that your body does not appear in the image. And when using a tripod, be careful that the leg of the tripod does not appear in the image.
- This lens is comprised of two lenses, and both the left and right lenses are read by one sensor. Depending on the camera, the image of the left lens is displayed on right side of the monitor, and the image of the right lens is displayed on the left side of the monitor.
Please refer to the camera's instructions for details.

This device complies with Part 15 of the FCC Rules.

Operation is subject to the following two conditions: (1) This device may not cause harmful interference, and (2) this device must accept any interference received, including interference that may cause undesired operation.

Do not make any changes or modifications to the equipment unless otherwise specified in the instructions. If such changes or modifications should be made, you could be required to stop operation of the equipment.

This equipment has been tested and found to comply with the limits for a class B digital device, pursuant to part 15 of the FCC Rules. These limits are designed to provide reasonable protection against harmful interference in a residential installation. This equipment generates, uses and can radiate radio frequency energy and, if not installed and used in accordance with the instructions, may cause harmful interference to radio communications.

However, there is no guarantee that interference will not occur in a particular installation. If this equipment does cause harmful interference to radio or television reception, which can be determined by turning the equipment off and on, the user is encouraged to try to correct the interference by one or more of the following measures:

- Reorient or relocate the receiving antenna.
- Increase the separation between the equipment and receiver.
- Connect the equipment into an outlet on a circuit different from that to which the receiver is connected.
- Consult the dealer or an experienced radio/TV technician for help.

Nomenclature

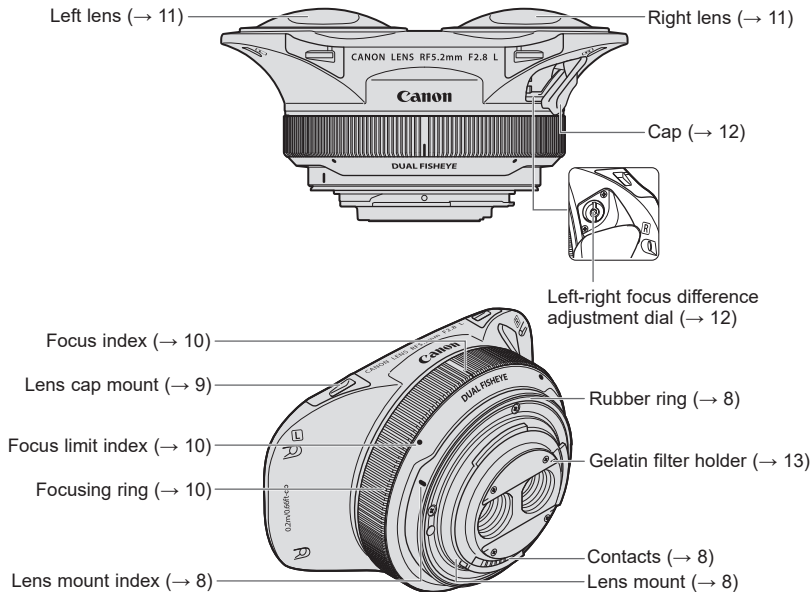

● For detailed information, reference page numbers are provided in parentheses (→ **).

1. Attaching and Detaching the Lens

Precautions when attaching the lens

When this lens is attached, the following functions may be limited and settings automatically changed, depending on the camera.

After detaching the lens, settings will remain as is and do not revert to the previous settings.

- Change still photo cropping/aspect ratio
- Dual Pixel RAW
- IS (Image Stabilizer) mode: Movie Digital IS
- Multi Shot Noise Reduction
- HDR PQ Settings
- HDR Mode: Auto Image Align
- Movie Recording Size: FHD
- Movie cropping
- HDR movie recording
- Shooting information display: Setting focus distance display
- Display performance: Power saving
- Change focus ring rotation direction
- Change RF lens MF focus ring sensitivity
- Lens aberration correction
 - Peripheral illumination correction
 - Distortion correction
 - Digital lens optimizer
 - Chromatic aberration correction

In order to revert to the previous settings, save the settings of the camera using the [Save/load cam settings on card] before attaching the lens. After detaching the lens, load the saved settings to revert to the previous settings.

Attaching and Detaching the Lens

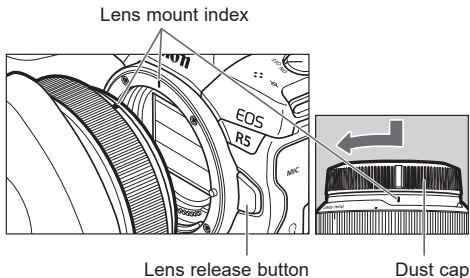

Attaching the Lens

Align the lens mount indexes of the lens and camera, and turn the lens clockwise until you hear a click.

Detaching the Lens

Turn the lens counterclockwise while pressing the camera's lens release button. Detach the lens once it has stopped turning.

Please refer to the camera's instructions for details.



- Set the camera's power switch to OFF when attaching or detaching the lens.
- Attach the lens cap before detaching the lens from the camera.
- After detaching the lens, place the lens with the rear end up and attach the dust cap to prevent the lens surface and contacts from getting scratched. Make sure the lens and dust cap mount indexes are aligned when attaching the dust cap.
- Contacts that are scratched, soiled, or have fingerprints on them may result in faulty connections or corrosion, which may lead to malfunctions. If the contacts get soiled, clean them with a soft cloth.
- The lens mount has a rubber ring to improve dust-resistance and water-resistance performance. This rubber ring may cause friction marks to appear around the camera's lens mount, although this will have no effect on usage.



- Rubber rings can be replaced at Canon Service Center. (chargeable)

2. Attaching and Detaching the Lens Cap

This lens projects out past the front frame. To protect the lens, use the special lens cap when not taking photos.

Attaching the Lens Cap

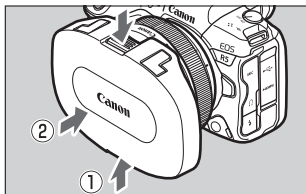

Attach (2) while pressing the buttons (1) on the top and bottom.

Detaching the Lens Cap

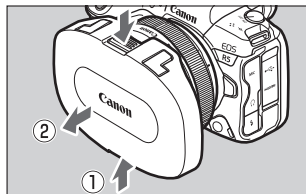

Detach (2) while pressing the buttons (1) on the top and bottom.



- After detaching the lens cap, do not touch the lens surface or allow it to come into contact with its surroundings.

3. Focusing ring

Turn the focusing ring to focus the lens. (AF shooting is not possible.)

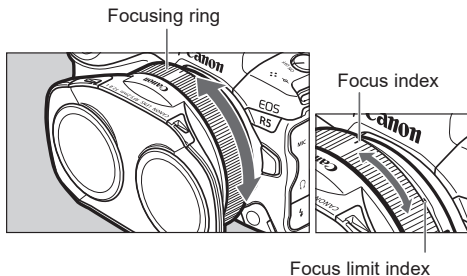

- This lens does not have a depth-of-field scale. Focus using the camera's Live View image.
- The focusing ring setting direction cannot be reversed for this lens.
- MF operation sensitivity cannot be changed with this lens.
- Focus may drift if the focusing ring is touched during use.
- Turn the left-right focus difference adjustment dial to adjust the focus if there is a difference in focus between the left and right lenses.

4. Checking/adjusting left and right focus

Checking Left and Right Focus

When first mounting this lens on the camera, or when using it after being transported for an extended period, use the following steps to check the difference between left and right focus.

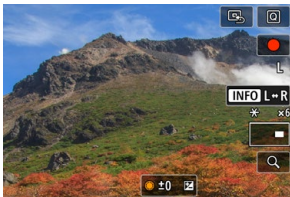

- 1 Display an enlarged image from the left lens, then turn the focusing ring to focus the lens.

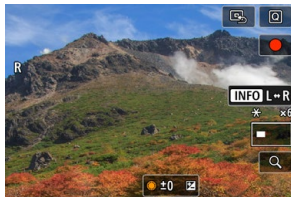

- 2 Press the <INFO> button on the camera to switch to an enlarged image from the right lens.
 - If the focus in the enlarged image from the right lens is correct after switching, adjustment is not needed. Only adjust the focus, using the steps on the following page, if the focus is not correct.



- Displaying an enlarged image from left lens.
 - Pressing the <Q> button on the camera allows you to change the enlargement ratio of the image from the left lens.
 - Pressing the <INFO> button on the camera allows you to switch display of enlarged images between the left and right lenses.
- Refer to the camera's instructions for further details.

Checking/adjusting left and right focus

Adjusting left and right focus

Leaving the enlarged image from the right lens showing, adjust using the following steps.

Left-right focus difference adjustment dial

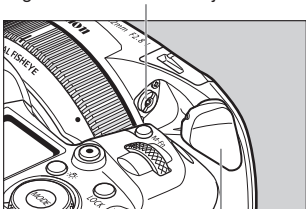

Cap

1 Detach the cap.

- Remember to firmly attach the cap after adjustment.

Left-right focus difference adjustment dial

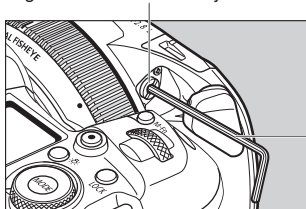

Hex key

2 Use the included hex key to turn the left-right focus difference adjustment dial to adjust focus.

- Turning the left-right focus difference adjustment dial only adjusts the focus of the right lens.
- Adjustment is complete once the focus in the enlarged image from the right lens is correct.

5. Filters (Sold separately)

This lens has a gelatin filter holder at the rear.

Cut the filter to the size that will fit in the filter index, and insert it into the holder.

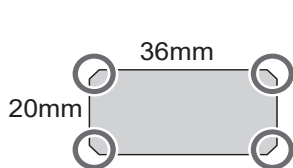

Filter indexes

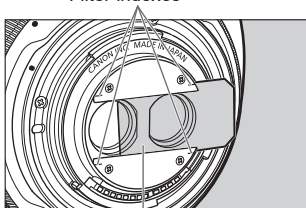

Gelatin filter

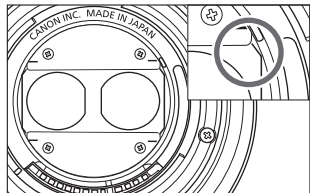

1 Cut the gelatin filter.

- The recommended size for the filter is 20mm high by 36mm wide.
- Cut off the corners before using.

2 Insert the gelatin filter into the holder from the right side.

3 Check if the gelatin filter is correctly inserted (whether it is within the frame, whether a corner is projecting out, etc.).

- If the filter projects outside, cut the corner.



- Only one filter may be used.
- Image ghosting may occur as a result of using a gelatin filter. Take care to avoid getting dirt or scratches on the gelatin filter.

6. Exposure

Photographing with AE (auto exposure) is possible at all focusing distances even with this lens attached.

- AE metering range is restricted to within the image circle in the left lens.
- As this lens is wide-angle, using flash photography on close-up subjects can cause very inaccurate AE exposure measurements. In that case, either use a separate light meter or check your images after capture.

Specifications

Focal Length/Aperture	5.2mm f/2.8
Lens Construction	10 groups, 12 elements (2 prisms) (per optical system)
Maximum Aperture	f/2.8
Minimum Aperture	f/16
Angle of View	Horizontal: 190°, Vertical: 190°, Diagonal: 190°
Min. Focusing Distance	0.2 m/0.66 ft.
Max. Magnification	0.03x
Baseline Length (Central point between left and right lenses)	Approx. 60 mm/2.36 in.
Width x Height x Length	Approx. 121.1 mm x 83.6 mm x 53.5 mm/4.77 x 3.29 x 2.11in.
Weight	Approx. 350 g/12.3 oz.
Lens Cap	Lens Cap 5.2
Case	LS1014

- Following shooting, the Exif data will display the focal length as 5 mm, but this due to a limitation in the display.
- The lens length is measured from the lens mount surface to the front end of the lens.
Add 21.0 mm/0.83 in. when including the lens cap and dust cap.
- The width, height, length and weight are for the lens itself only.
- Close-up Lens 250D/500D cannot be attached because there is no size that fits the lens.
- You cannot use extenders.
- All data listed is measured according to Canon standards.
- Product specifications and appearance are subject to change without notice.

Canon