

Digital Cinema Lens

CN-E20-50mm T2.4 L F / CN-E20-50mm T2.4 L FP
 CN-E45-135mm T2.4 L F / CN-E45-135mm T2.4 L FP

ENG OPERATION MANUAL

Before using the product, make sure to read the "GENERAL SAFETY INFORMATION" and be sure to use the product correctly.

This product comes with the following documents:

- Operation Manual "Before Using The Product" (Included with the product)
- Operation Manual "Regulations" (Included with the product)
- Operation Manual (Web)
- Depth-of-field (Web)

PRODUCT LIST

Make sure all of the following items are included in the packing box. If you find any item missing, please contact your dealer or Canon Inc.

- ① Lens body
- ② Lens cap
- ③ Rear lens cap
- ④ Attachment holder
- ⑤ Operation Manual "Before Using The Product"
- ⑥ Operation Manual "Regulations"

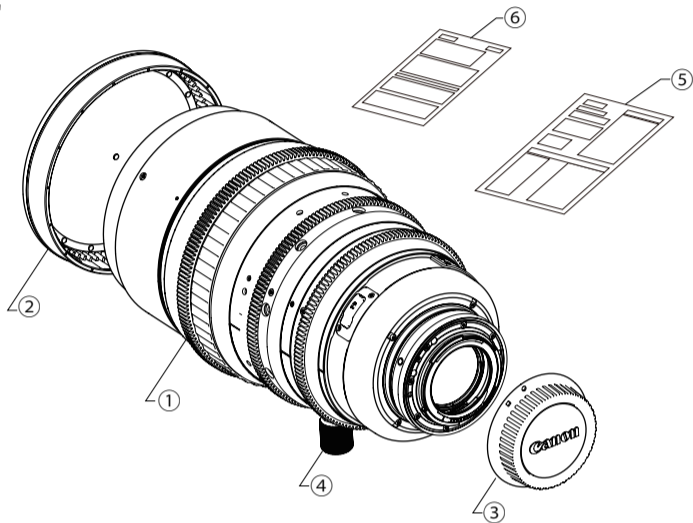

The illustrations in this manual show CN-E20-50mm T2.4 L F unless otherwise specified. The shapes of product may vary depending on models and specifications.

MOUNTING AND CONNECTING

For PL mount, read the following instructions before mounting the lens.

1. The PL mount supports Cooke's /i Technology, so make sure that the camera is set to "/i".
2. Do not mount the lens if the camera is set to a mount communication mode other than "/i". Doing so could result in malfunction.

A variety of professional camera accessories are available using $\Phi 15$ mm and $\Phi 19$ mm rod adaptors. (When using a $\Phi 19$ mm rod, attach the supplied attachment holder to the lens holder.)

- Note**
1. Before mounting the lens on the camera, make sure that the power of camera and the power of supply equipment are turned off.
 2. Be sure to use the lens holder when mounting the lens on a camera. Be sure to avoid applying excessive weight to the lens mount when the lens is mounted on a lens support.

1. Attach the lens to the camera tightly so that both mounting surfaces are in complete contact.

Note
 For details on how to attach the lens, refer to the camera's operation manual as well.

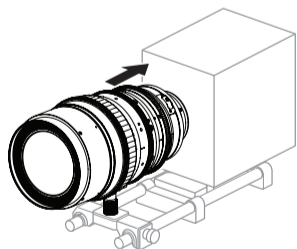

2. Secure the attachment holder on the lens support using the clamping screw supplied with the lens support.

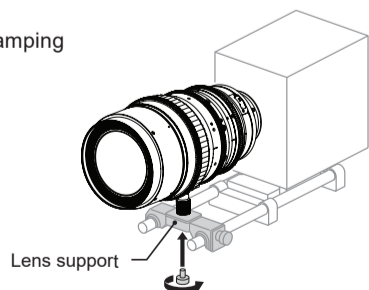

3. Push the lens toward the camera until both mounting surfaces are in complete contact and clamp the lens support to the rods.

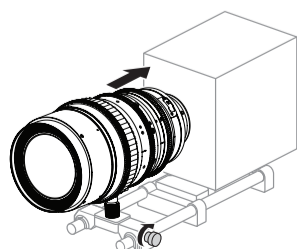

NAMES OF PARTS

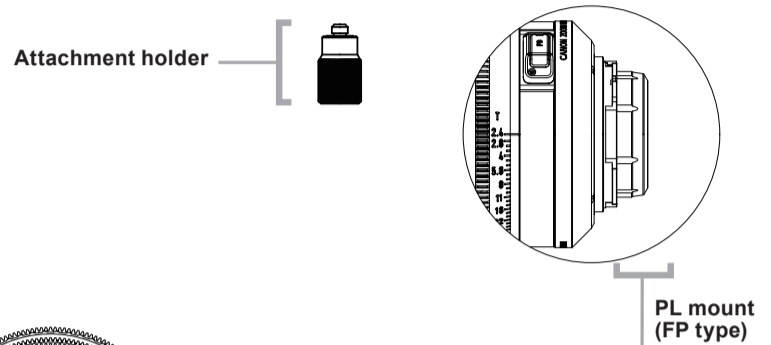
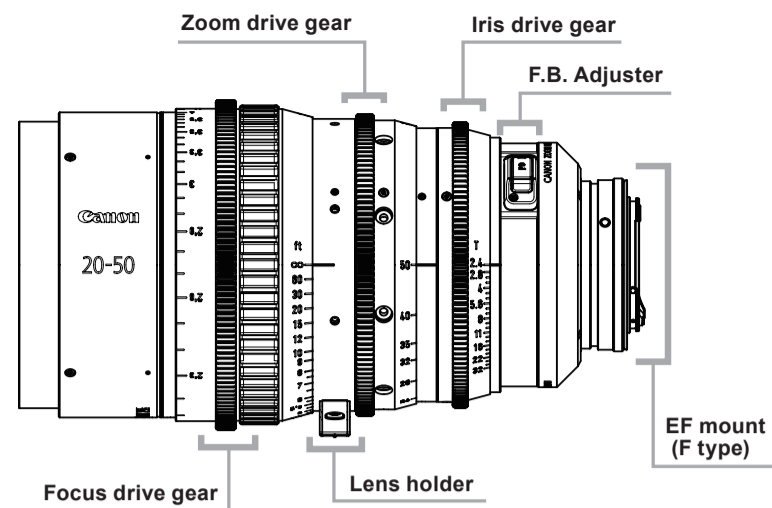

LEMO 4-pin Connector

PL mount lenses are equipped with a LEMO 4-pin connector. It connects to external devices that support Cooke's /i Technology.

BACK FOCUS ADJUSTMENT

If the image formation plane of the lens and the focal plane of the camera are not aligned, the image will not be in focus when zooming, resulting in out-of-focus images.

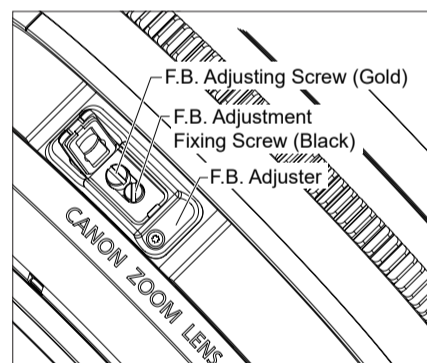

1. Open the rubber cap of F.B. adjuster and loosen the F.B. adjusting fixing screw (black) using the standard screwdriver.
2. Select an object at an appropriate distance*. Use any object with sharp contrast to facilitate the adjustment work.
3. Set the iris fully open.
4. Set the lens to the telephoto angle by turning the zoom ring.
5. Bring the object into focus by turning the focus ring.
6. Set the lens to the widest angle by turning the zoom ring.
7. Turn the F.B. adjusting screw (gold) with a standard screwdriver to focus.
8. Repeat steps 4 to 7 a few times until the object is brought into focus both at the widest end and the telephoto end.
9. After the back focus adjustment is completed, tighten the F.B. adjusting fixing screw. Then close the rubber cap.

* CN-E20-50mm T2.4 L F / CN-E20-50mm T2.4 L FP : approx. 0.9-1.8 m, 3-6 ft
 CN-E45-135mm T2.4 L F / CN-E45-135mm T2.4 L FP : approx. 1.8-3.7 m, 6-12 ft

CN-E20-50mm T2.4 L F / CN-E20-50mm T2.4 L FP

EXTERNAL VIEW

F type (EF mount)

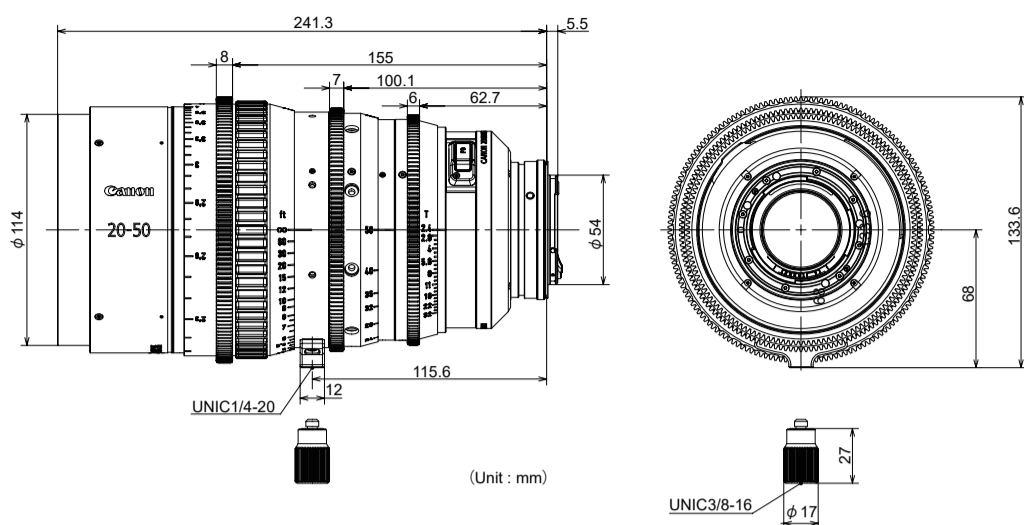

FP type (PL mount)

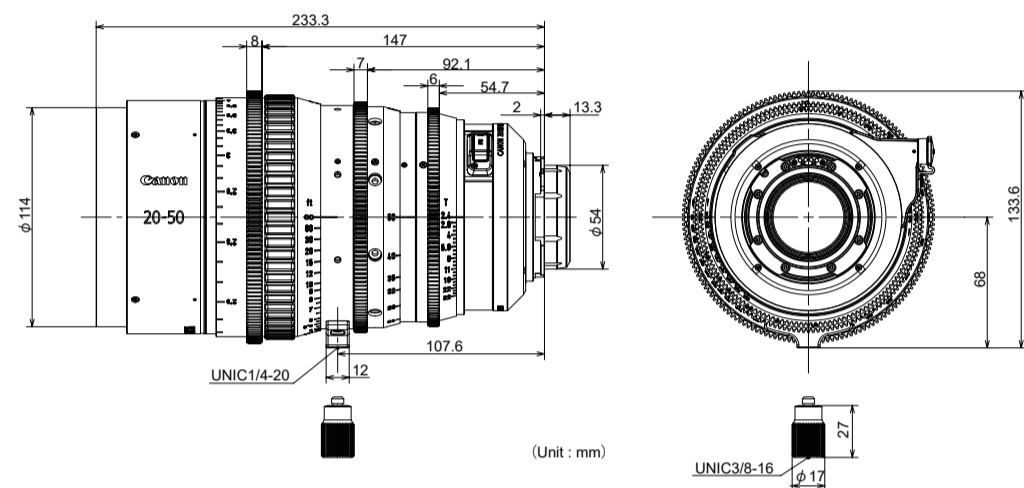

Spur gear specifications

	Focus drive gear	Zoom drive gear	Iris drive gear
Number of teeth	162	148	140
Module	0.8	0.8	0.8
P.C.D.	129.6 mm	118.4 mm	112 mm
Angular rotation	300°	93.5°	55°

SPECIFICATIONS

		CN-E20-50mm T2.4 L F (EF mount) CN-E20-50mm T2.4 L FP (PL mount)			
Focal Length		20-50 mm			
Maximum Relative Aperture (T no)		1:2.4			
Iris Blade		11			
Image size		Φ46.4 mm			
Image Coverage (H / V)		35.7×20.1 mm	38.1×20.1 mm	36×24 mm	40.96×21.6 mm
Aspect Ratio		1.78 : 1	1.9 : 1	1.5 : 1	1.9 : 1
Angular Field of View (H / V)	Wide angle end	83.5°×53.4°	87.2°×53.4°	84.0°×61.9°	91.4°×56.7°
	Telephoto end	39.3°×22.7°	41.7°×22.7°	39.6°×27.0°	44.5°×24.4°
Minimum Object Distance (M.O.D.)		0.6 m / 2' (from the image sensor)			
Object Dimensions at M.O.D. (H / V)	Wide angle end	64.9×36.6 cm	69.3×36.6 cm	65.5×43.7 cm	74.5×39.3 cm
	Telephoto end	24.7×13.9 cm	26.4×13.9 cm	24.9×16.6 cm	28.4×15.0 cm
Front Diameter		Φ114 mm			
Thread for filters		Φ112 mm P1.0			
Size (W × H × L)		Approx. 131.2×133.6×241.3 mm (EF mount) Approx. 131.2×133.6×233.3 mm (PL mount)			
Weight		Approx. 3.3 kg			

A variety of professional camera accessories compatible with the Φ15 mm and Φ19 mm rod system can be used with this lens.

Note

This lens is a full manual lens for shooting movies.

- When used to shoot still images or when manual operations are performed in AE or other Auto modes, the lens may not operate properly or the indications may not be correct.
- Do not operate the lens during initialization of the camera settings.
- This lens is developed primarily for movie production, and have a color balance typical for movies. This means that the color reproduction is warmer than that of EF lenses which are basically used to shoot still images. Therefore, when using both types of lens together, adjust the color balance (redo the white balance etc.) as necessary.
- In general, the depth of field becomes shallow and the focusing range becomes extremely narrow near the widest aperture and when shooting a subject at close range. In addition, this tendency increases for lenses with longer focal lengths. When shooting images, carefully check the focusing condition using the zoom mode of the finder or other means, and shoot a sufficient number of test images before performing focus operations.

(for EF mount Lens only)

- The T number is printed on the iris ring of this lens, but the F value may be displayed on the camera side.
- Information of the focal length displayed on the camera side omits the figures below the decimal point.

CN-E45-135mm T2.4 L F / CN-E45-135mm T2.4 L FP

EXTERNAL VIEW

F type (EF mount)

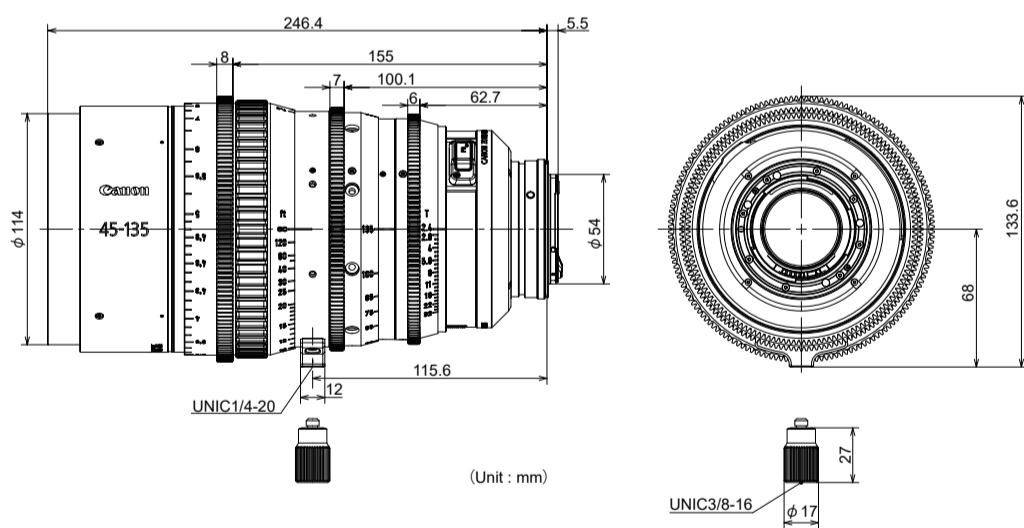

FP type (PL mount)

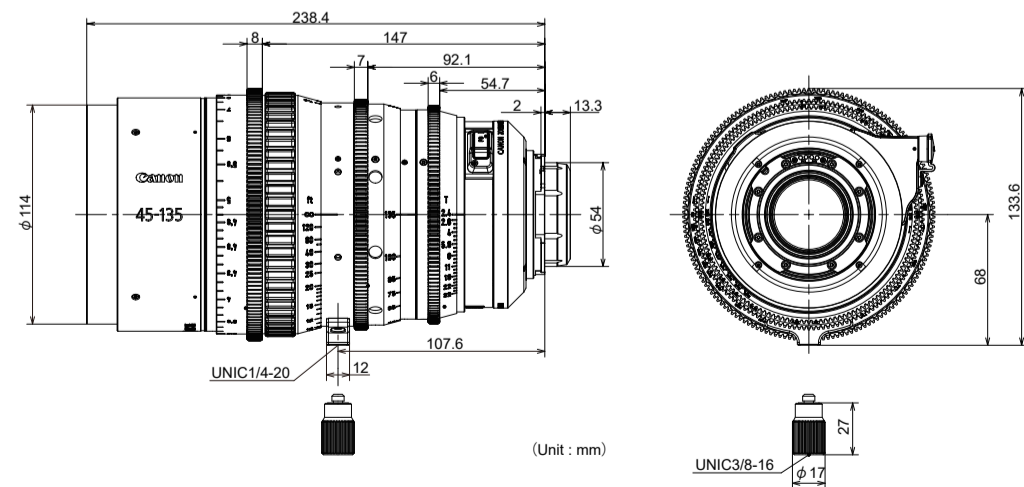

Spur gear specifications

	Focus drive gear	Zoom drive gear	Iris drive gear
Number of teeth	162	148	140
Module	0.8	0.8	0.8
P.C.D.	129.6 mm	118.4 mm	112 mm
Angular rotation	300°	93.5°	55°

SPECIFICATIONS

		CN-E45-135mm T2.4 L F (EF mount) CN-E45-135mm T2.4 L FP (PL mount)			
Focal Length		45-135 mm			
Maximum Relative Aperture (T no)		1:2.4			
Iris Blade		11			
Image size		Φ46.4 mm			
Image Coverage (H / V)		35.7×20.1 mm	38.1×20.1 mm	36×24 mm	40.96×21.6 mm
Aspect Ratio		1.78 : 1	1.9 : 1	1.5 : 1	1.9 : 1
Angular Field of View (H / V)	Wide angle end	43.3°×25.2°	45.9°×25.2°	43.6°×29.9°	48.9°×27.0°
	Telephoto end	15.1°×8.5°	16.1°×8.5°	15.2°×10.2°	17.3°×9.1°
Minimum Object Distance (M.O.D.)		1.0 m / 3'4" (from the image sensor)			
Object Dimensions at M.O.D. (H / V)	Wide angle end	67.2×37.8cm	71.7×37.8cm	67.7×45.2cm	77.1×40.6cm
	Telephoto end	21.6×12.1cm	23.0×12.1cm	21.7×14.5cm	24.7×13.0cm
Front Diameter		Φ114 mm			
Thread for filters		Φ112 mm P1.0			
Size (W × H × L)		Approx. 131.2×133.6×246.4 mm (EF mount) Approx. 131.2×133.6×238.4 mm (PL mount)			
Weight		Approx. 3.4 kg			

A variety of professional camera accessories compatible with the Φ15 mm and Φ19 mm rod system can be used with this lens.

Note

This lens is a full manual lens for shooting movies.

- When used to shoot still images or when manual operations are performed in AE or other Auto modes, the lens may not operate properly or the indications may not be correct.
- Do not operate the lens during initialization of the camera settings.
- This lens is developed primarily for movie production, and have a color balance typical for movies. This means that the color reproduction is warmer than that of EF lenses which are basically used to shoot still images. Therefore, when using both types of lens together, adjust the color balance (redo the white balance etc.) as necessary.
- In general, the depth of field becomes shallow and the focusing range becomes extremely narrow near the widest aperture and when shooting a subject at close range. In addition, this tendency increases for lenses with longer focal lengths. When shooting images, carefully check the focusing condition using the zoom mode of the finder or other means, and shoot a sufficient number of test images before performing focus operations.



(for EF mount Lens only)

- The T number is printed on the iris ring of this lens, but the F value may be displayed on the camera side.
- Information of the focal length displayed on the camera side omits the figures below the decimal point.

GENERAL SAFETY INFORMATION

The safety warnings and cautions provided on the product or in this operation manual must be observed. Failure to observe these warnings and cautions may result in injury or accident. Read this operation manual carefully to familiarize yourself with its contents and ensure that you can operate the product properly. Also, store this manual in a safe place where it can easily be referenced whenever necessary.

This operation manual uses the following symbols and terms to identify hazards in order to prevent accidents.

 WARNING	This indicates a potentially hazardous situation which, if not heeded, may result in death or serious injury to you or others. Be sure to heed all warning notices to ensure safe operation at all times.
 CAUTION	This indicates a potentially hazardous situation which, if not heeded, may result in a minor injury to you or others, or damage to property.
NOTE	This indicates cautions and recommendations for operation. It contains information which, if not heeded, may result in this product failing to function properly. These notices also contain useful information for operation.

WARNING

Do not stare at the sun or other bright objects through the lens. It may injure your eyes.

CAUTION

1. Ensure that all mountings are securely tightened. If a mounting becomes loose, parts may fall off and cause injury.
2. Inspect mountings regularly (about every six months to one year) to ensure they are securely tightened. If a mounting becomes loose, parts may fall off and cause injury.

NOTE

1. Do not expose the lens to strong impact. Striking or dropping the lens may cause the malfunction of the product.
2. This product is not waterproof. Take measures to avoid direct contact with rain, snow, or moisture. Otherwise it may cause the malfunction of the product.
3. Take measures to avoid sudden changes in temperature where the lens is used, which may prevent operation temporarily if condensation forms in the lens.

WARNING

If any of the following situations occurs, immediately dismount the lens from the camera and contact your Canon sales representative or dealer.

- Smoke, fumes, or unusual noises
- Entry of foreign objects (such as liquid or metal objects) inside the product

NOTE

1. Clean off any dust on the lens surface using a lens blower or a soft lens brush. In case of getting fingerprints or stains on the lens, use a clean cotton cloth moistened with commercial lens cleaning fluid, or use lens cleaning paper. Gently wipe in a spiral pattern from the center of the lens. Be careful not to rub dust across the lens, which may scratch the lens surface.
2. Routine inspection about once a year is recommended, depending on the conditions and environment of use. Request overhaul, if needed.

CAUTION

Always attach the lens cap, hood cap, dust cap or covers before storage. Storing the lens without the caps or covers attached poses a risk of fire if the lens concentrate light in direct sunlight.

NOTE

Immediately wipe off any moisture on the lens from misty or foggy environments, using a dry cloth. Seal the lens in a plastic bag with a desiccant (preferably new) to prevent moisture inside. Otherwise it may cause the mold or the malfunction of the product.

TO THE CUSTOMER

1. Canon shall bear no responsibility for damage resulting from improper operation of this product by the customer.
2. Canon shall make no guarantees about the product quality, functions, or operation manual and its marketability and suitability for the customer's purpose. Moreover, Canon shall bear no responsibility for any damage, direct or incidental, that results from usage for the customer's purpose.
3. The product specifications, configuration, and appearance are subject to change without prior notice.
4. For further information on repairs, maintenance, or adjustments not mentioned in this operation manual, contact your Canon sales representative or dealer.
5. Note that Canon may be unable to undertake servicing or repair of a product if it is modified without consulting Canon or your Canon sales representative.

HANDLING THE PRODUCT

DEALING WITH ABNORMALITIES

MAINTENANCE AND INSPECTION

STORAGE

CANON INC.
30-2, Shimomaruko 3-chome, Ohta-ku, Tokyo 146-8501, Japan

All rights reserved. No part of this operation manual may be reproduced or copied in any form or by any means without the written permission of Canon Inc.

[memo]